

# 7 TANK SEQUENTIAL FILTER (51-87 STAGER)

## 7 TANK SEQUENTIAL FILTER BACKWASH ONLY

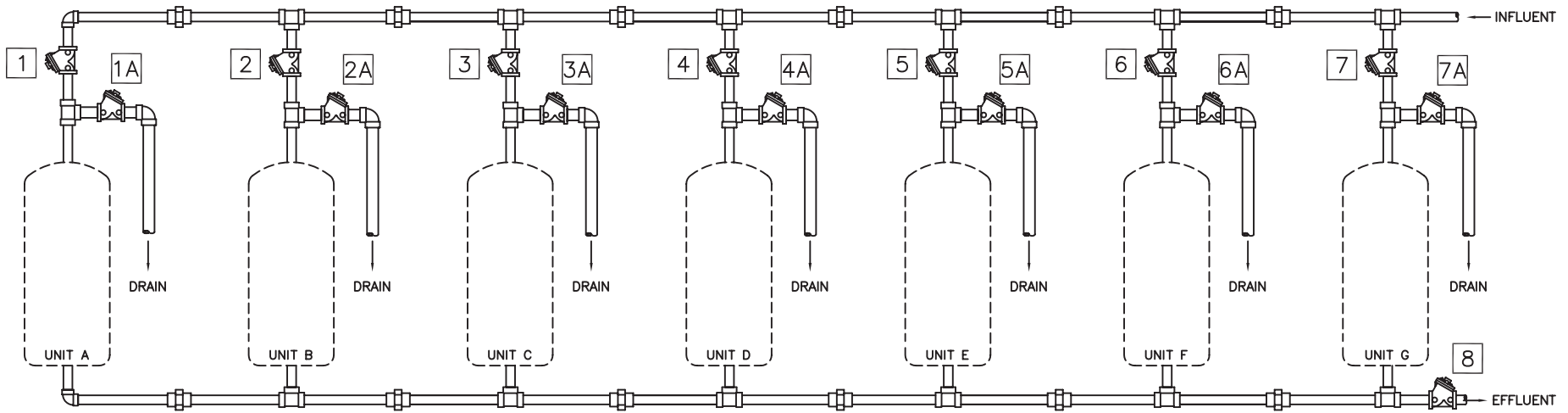

**NOTE:**

1. ALL OTHER PORTS PRESSURIZED.
2. VALVES 1A,2A,3A,4A,5A,6A,7A,8 ARE NORMALLY OPEN PRESSURE TO CLOSE.
3. VALVES 1,2,3,4,5,6,7 ARE NORMALLY CLOSED, PRESSURE TO OPEN.

NOTCH	POS.	FUNCTION	PORTS VENTED (NOTE 1)	VALVES OPEN
A	8	SERVICE	8	1,2,3,4,5,6,7,8
B	1	BACKWASH UNIT A	1	1A,2,3,4,5,6,7
C	2	BACKWASH UNIT B	2	1,2A,3,4,5,6,7
D	3	BACKWASH UNIT C	3	1,2,3A,4,5,6,7
E	4	BACKWASH UNIT D	4	1,2,3,4A,5,6,7
F	5	BACKWASH UNIT E	5	1,2,3,4,5A,6,7
G	6	BACKWASH UNIT F	6	1,2,3,4,5,6A,7
H	7	BACKWASH UNIT G	7	1,2,3,4,5,6,7A

SERIES 51-87 STAGER

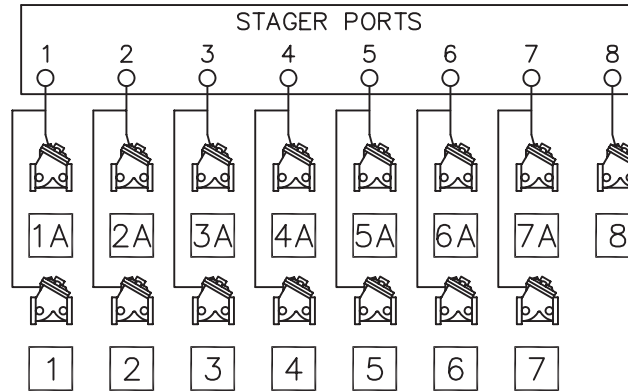

PRINTED IN U.S.A.

B	MOVED SVC POS. TO NOTCH "A"	NONE	MSM	07SEP04	
A	INITIAL RELEASE	NONE	JWB	31JUL01	VKP
REV	DESCRIPTION	ECO	DWN	DATE	APVD
		16605 West Victor Rd New Berlin, WI 53151 262-326-0100 www.aq-matic.com			
<b>7 TANK SEQUENTIAL FILTER BACKWASH ONLY</b>					
SCALE	DRAWN	DATE	DWG. NO.		
N/A	JWB	31JUL01	1078287		